



## XPANDX WORKSHOP TABLE ASSEMBLY INSTRUCTIONS

1. Attach bottom brace (#4) to post (#2), using 5/16 x 3/4 hex head bolts, nuts, and lockwasher
2. Assemble apron rail (#5) to post (#2) using 5/16 x 3/4 hex head bolts, nut, and lockwasher.
3. Connect adjustable leg extension (#1) to post at lower set of holes using 1/2 x 7/8 hex head bolts, washer, square nut and nut retainer. Connect angle corner brace (#7) L.H. And (#7) R.H. Using 5/16 x 3/4 hex head bolts, nut, and lockwasher.
4. Connect diagonal corner brace (#6) to post at upper set of holes using 5/16 x 3/4 hex head bolts, nuts, and lockwasher..
5. Attach table top using round head sheet metal screws. Connect L.H. & R.H.
6. Diagonal corner brace (#9) using 5/16 x 3/4 hex head bolts, Nut, and washer.
7. Attach connecting apron (#3) to side of post (#2).
8. Continue the same process to build additional tables.

### XPANDX TABLE PARTS

Part #	Description	Qty.
1	Adjustable leg extensions (opt.)	8
2	Leg	8
3	Connecting apron	1
4	Bottom brace = (table length)	4
5	Apron rail 48"	2
6	Apron rail = (table length)	8
7	Left & right hand brace	4
8	Diagonal corner brace	4
9	Left & right diagonal corner brace	8
	Hardware:	96
	1/2 x 7/8 hex head bolt, nut, ret.,	36

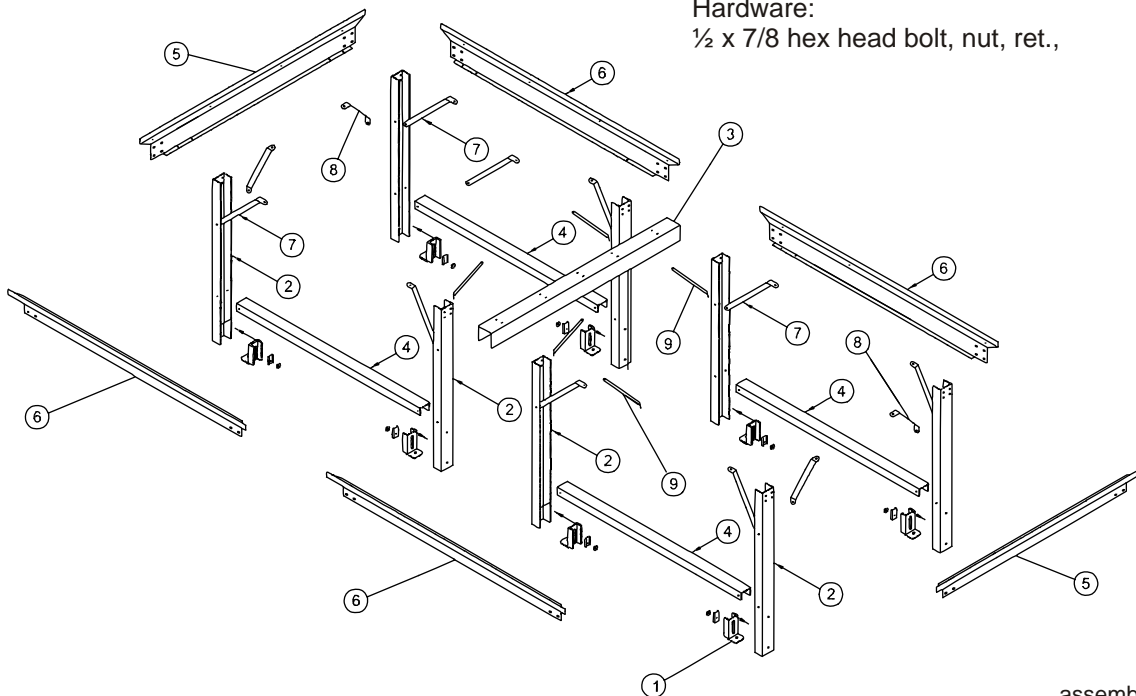

assembl2.pdf